

TURBONICS, INC.

MANUFACTURER OF HYDRONIC FAN COILS

KICKSTER™ WM+ SERIES HYDRONIC FAN COILS

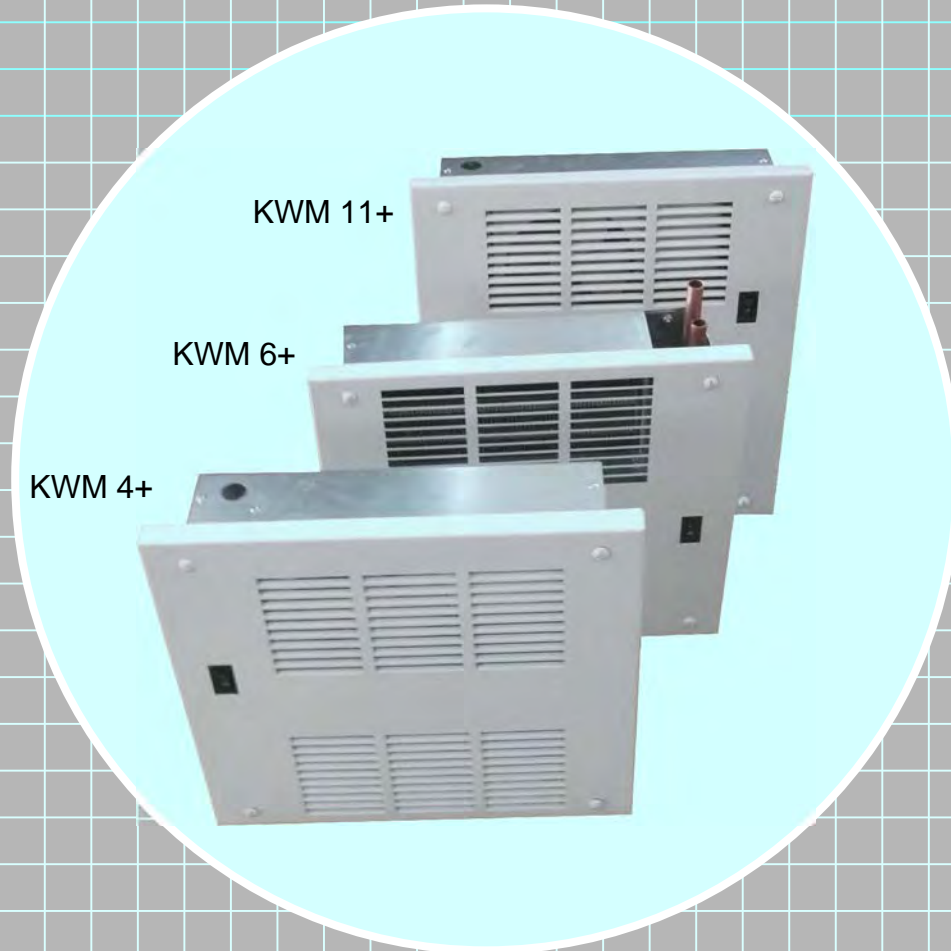

INSTALLATION & APPLICATION MANUAL

KICKSTER™ WM+ SERIES 3K to 11K Hydronic Fan Coils
Model KWM 4+, KWM 6+, and KWM 11+ WALL MOUNT UNITS
ALL UNITS CAN BE ROTATED VERTICALLY UP OR DOWN



KICKSTER™ WM+ SERIES HYDRONIC FAN COILS ARE CSA LISTED
IN ACCORDANCE WITH CURRENT US & CANADIAN STANDARDS
ASSEMBLED IN THE USA TO ORDER FOR COMPETITIVE DELIVERY.

INTRODUCING THE NEW KICKSTER™ WM+ SERIES HYDRONIC WALL MOUNT FAN COILS, ANOTHER BRILLIANT INNOVATION FROM TURBONICS, INC. A LEADING MANUFACTURER OF HYDRONIC FAN COILS IN THE UNITED STATES.

The new “K” series of Wall Mount hydronic Fan Coils are completely “Konstruction Ready”. Wall Mount units are vertically rotatable allowing either top or bottom piping and wiring connections for Contractor Friendly installs.

KWM’s fit between studs and are to be installed before drywall.*

KWM’s can be mounted in either a piping from below or above configuration.**

KWM’s have switches that can be rotated depending on mounting orientation and depth of drywall.

KWM’s have pipes that extend beyond the shell of the unit for easy installation of piping.***

KWM’s have their cover’s wrapped separately for quick trim installation after drywall finish.

KWM’s come with a pre-construction internal “Debris Cover” removed just before cover installation.

KWM’s use “4 corner internal mounting” to provide a closer wall fit against variations in drywall finish.

KWM;s follow the basic and traditional thermodynamic rules of “circular” airflow patterns.

KWM’s use the tried and true Propeller Fan Technology which has become a cornerstone of Turbonics.

KWM’s use high output heater cores designed to extract the maximum amount of energy possible

KWM’s heater cores output capacity is verified by ISO 9000 certified factory in business for 50 years.

KWM’s 4+ and 6+ cores use a standard 6 or 8-pass serpentine flow 5/8" copper and have 6 fins per inch.

KWM’s 11+ heater cores use 18-pass 3/8" copper connected to 5/8" manifolds and have 8 fins per inch.

KWM’s use proven components and operating characteristics of fan coils used for over 15 years.

KICKSTER™ WM+ FAN COILS, BASED ON CAPACITY ARE THE MOST COMPACT AND RELIABLE WALL MOUNTED HYDRONIC FAN COILS IN THE BUSINESS. THEY CAN BE USED WITH HEATED POTABLE WATER OR OTHER GLYCOL/WATER FLUIDS. THEY CAN BE CONNECTED TO VARIOUS TYPES OF WATER HEATERS OR BOILERS UTILIZING VIRTUALLY ANY SOURCE OF ENERGY FROM NATURAL GAS, PROPANE OR OIL TO SOLAR, GEOTHERMAL OR WASTE HEAT FROM PROCESS.

* Stud mount brackets can be moved up or rotated for “on drywall” installations

** Units are shipped to be installed with pipes from above. If piping from below ask for a DD (Double Down) cover.

*** Units can be slipped into drywall finished walls as long as “Flexible Connector Kits” are used.

KICKSTER™ WM+

KWM 4+, KWM 6+, KWM 11+

Product Description KWM 4+ R STN

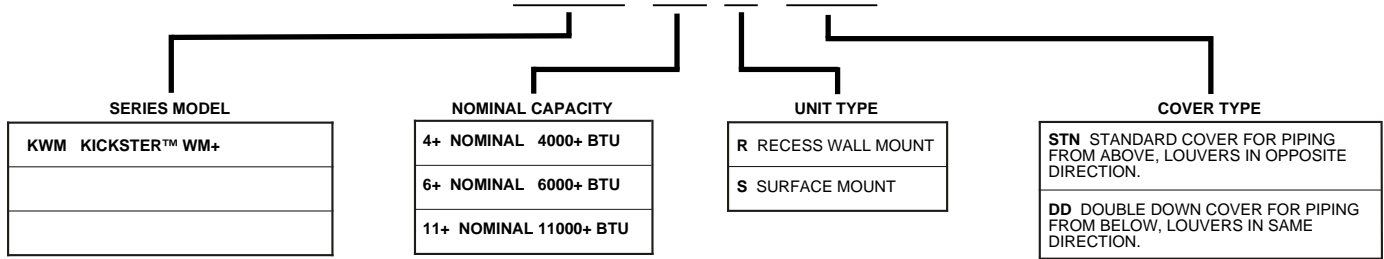

KWM 11+ UNIT SHOWN WITH DOUBLE DOWN COVER

KICKSTER™ WM+ SERIES PERFORMANCE CAPACITY

*Ratings and Motor Data			Pressure Drop - Ft. Wtr			Heating Output Ratings**				
Model #	Fan Spd/Amps	CFM	1 GPM	2 GPM	4 GPM	120 Deg	140 Deg	160 Deg	180 Deg	200 Deg
KWM 4+	Lo .5 Amp	95	.5'	1.5'	6.0'	2300	3200	4100	5000	5900
KWM 4+	Hi .55 Amp	140				2800	3900	5000	6100	7200
KWM 6+	Lo .5 Amp	95	.65'	2.0'	7.2'	2600	3600	4600	5600	6600
KWM 6+	Hi .55 Amp	140				3300	4500	5700	6900	8100
KWM 11+	Lo .5 Amp	110	1.0'	3.0'	9.0'	3500	4700	6000	7300	8600
KWM 11+	Hi .55 Amp	165				4200	5800	7400	9000	10600

* Heat Ratings based on 2 GPM and 65°F Entering Air.
For 1 GPM multiply by .95 factor.

**System should be designed on Lo Speed as outputs on Hi Speed may be associated with fan noise
**40% Glycol reduces output by as much as 15%

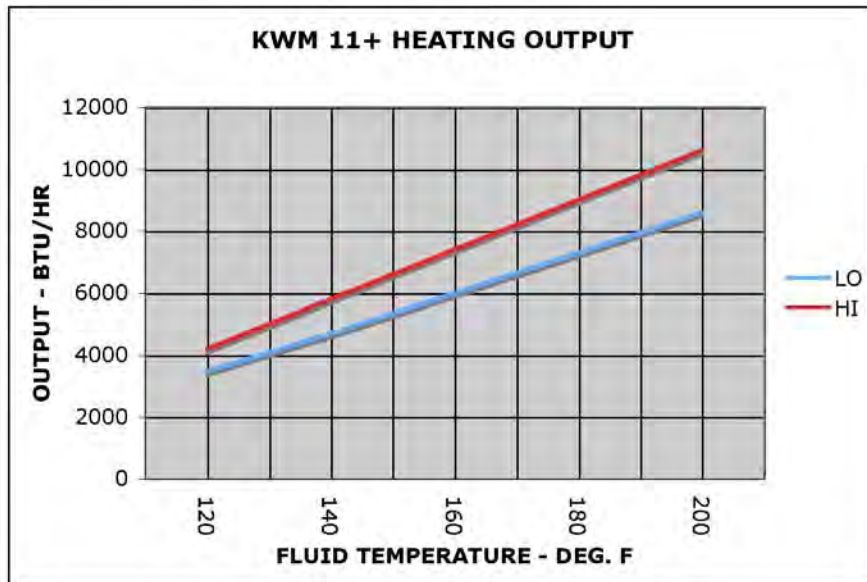
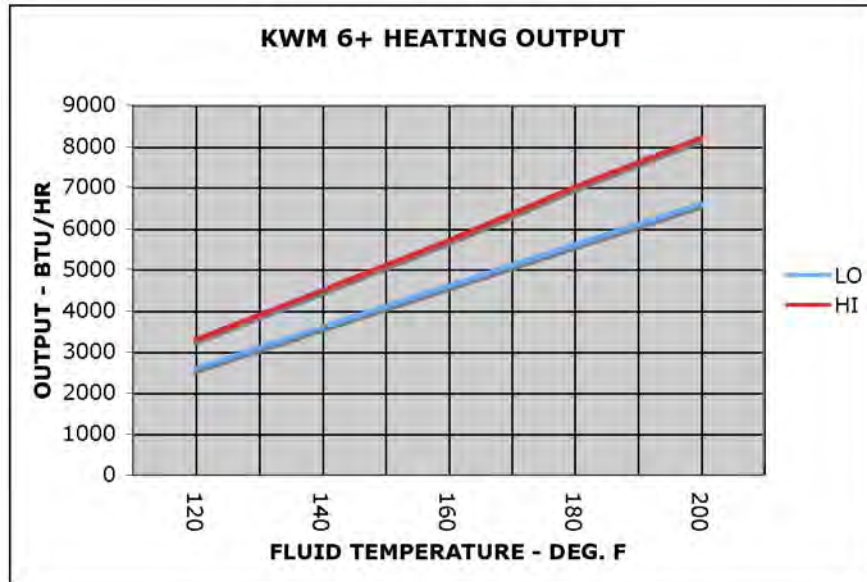
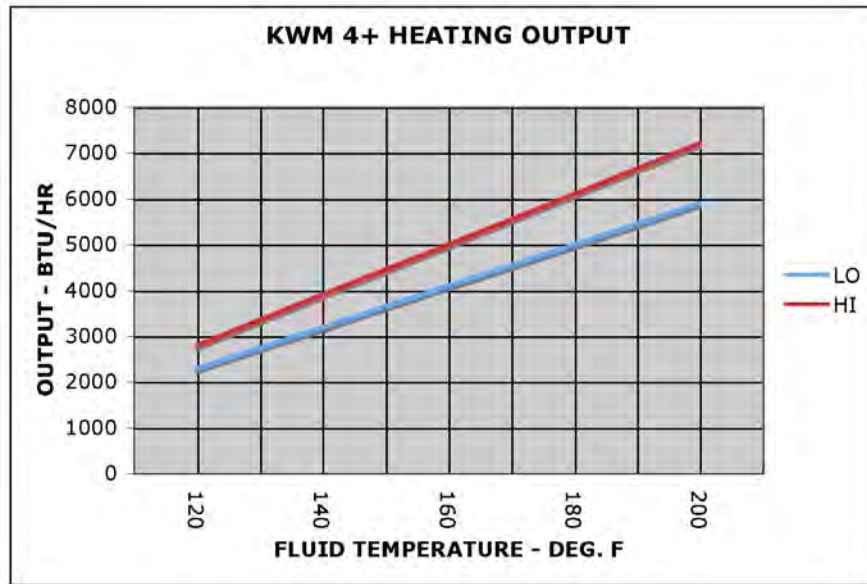

KICKSTER™ WM+

DIMENSIONAL DATA

NOTE: KWM 4+ HEATER CORE FEATURES 6-PASS SERPENTINE FLOW PATTERN 5/8" COPPER WITH 6 FIN PER INCH ALUMINUM

NOTE: KWM 6+ HEATER CORE FEATURES 8-PASS SERPENTINE FLOW PATTERN 5/8" COPPER WITH 6 FIN PER INCH ALUMINUM

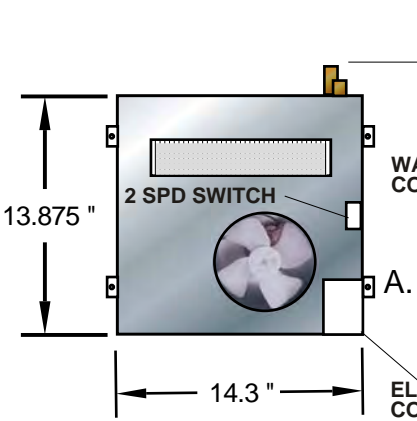

FRONT VIEW

KWM 4+

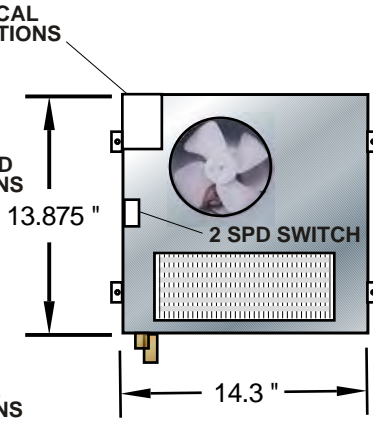

FRONT VIEW

KWM 6+

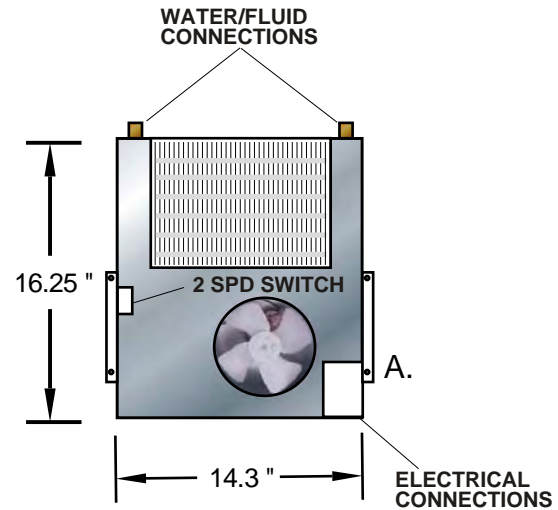

FRONT VIEW

KWM 11+

NOTE: THE KWM 6+ IS SHOWN IN OPTIONAL PIPING DOWN POSITION WITH REQUIRED DOUBLE DOWN COVER.

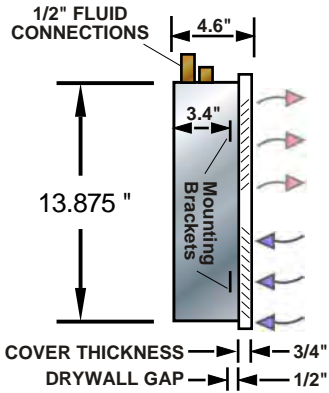

SIDE VIEW

KWM 4+

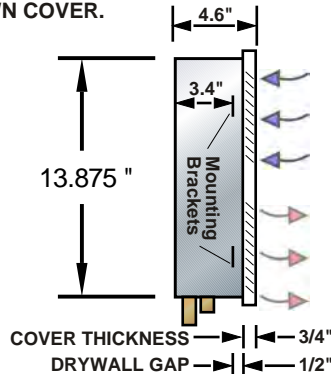

SIDE VIEW

KWM 6+

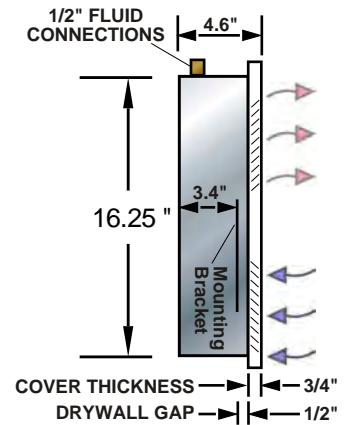

SIDE VIEW

KWM 11+

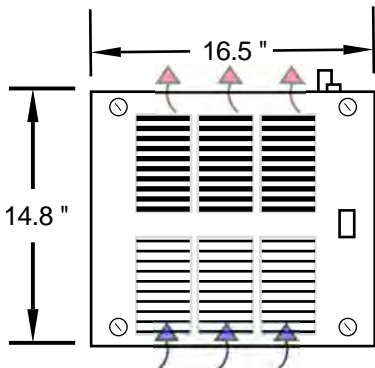

STANDARD COVER COVER VIEW

KWM 4+

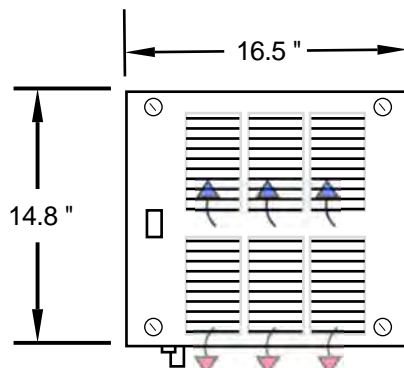

DOUBLE DOWN COVER COVER VIEW

KWM 6+

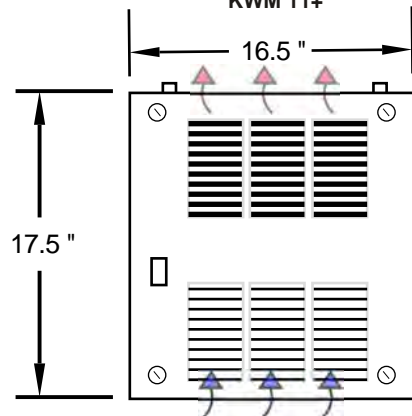

STANDARD COVER COVER VIEW

KWM 11+

KICKSTER™ WM+

WIRING DIAGRAM (Standard Control Option)

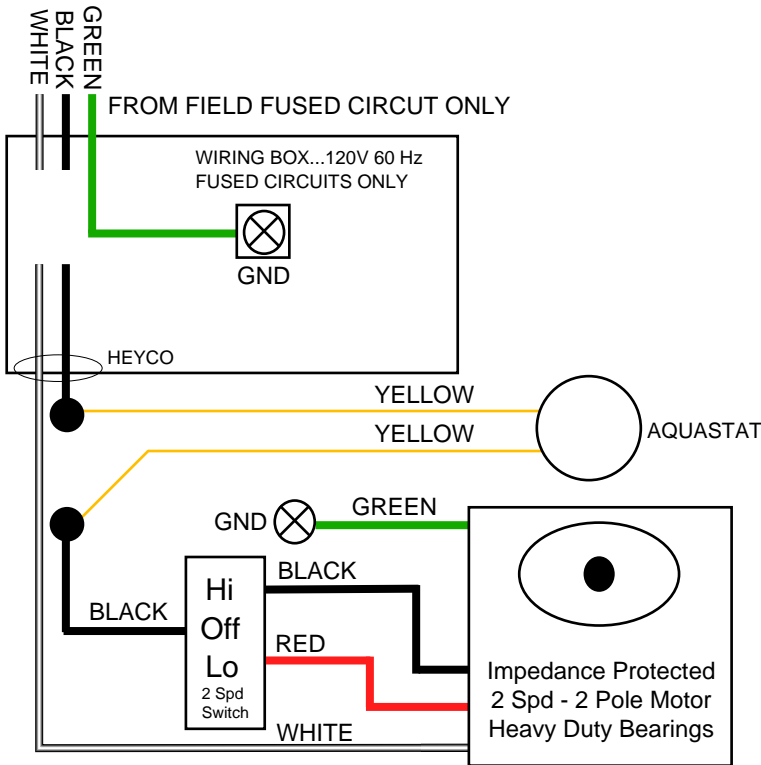

KWM 4+, 6+ AND KWM 11+ STANDARD WIRING DIAGRAM

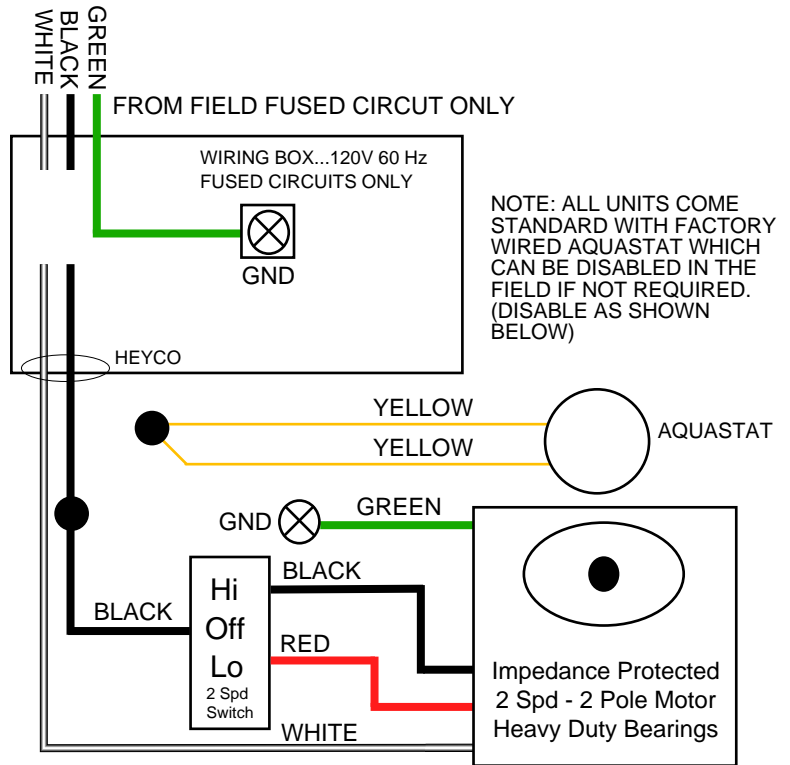

KWM 4+, 6+ AND KWM 11+ WIRING WITH AQUASTAT DISABLED

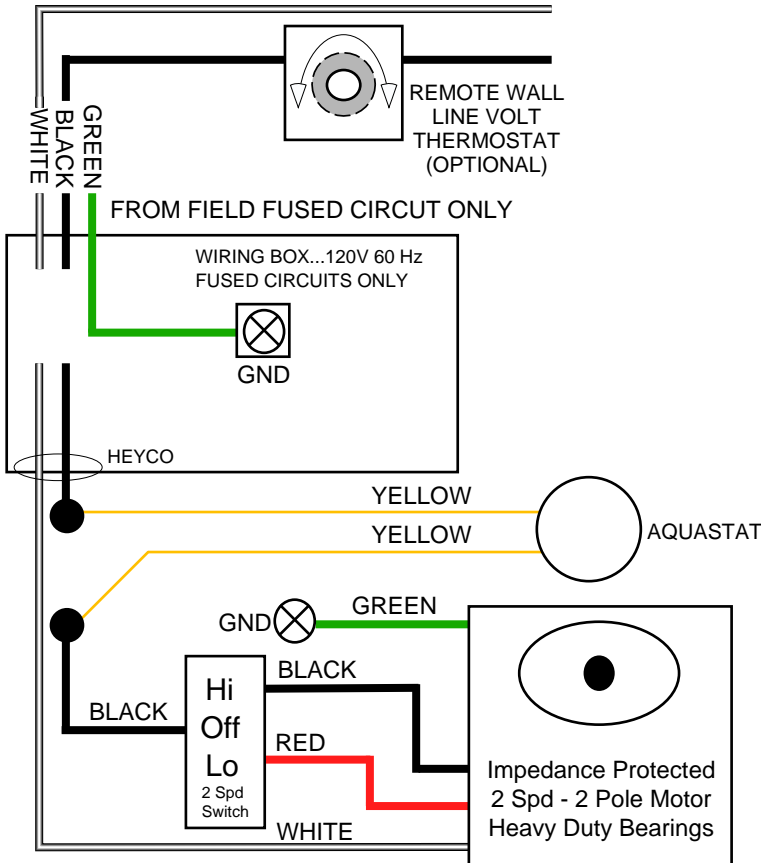

KWM 4+, 6+ AND KWM 11+ WITH REMOTE WALL LINE VOLTAGE THERMOSTAT

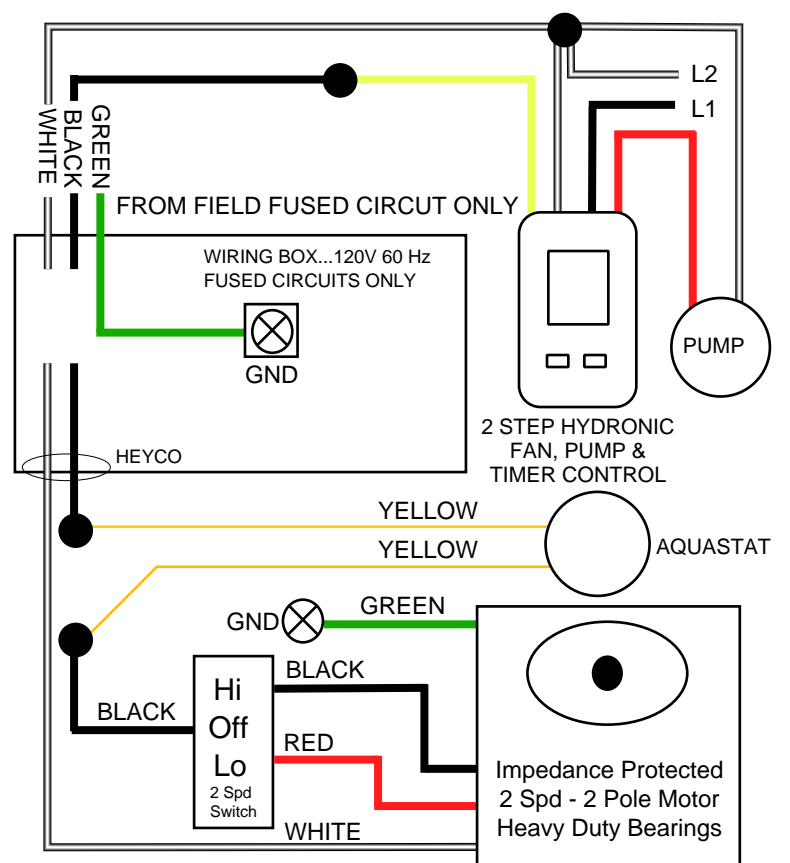

KWM 4+, 6+ AND KWM 11+ WITH 2 STEP HYDRONIC FAN, PUMP & TIMER CONTROL

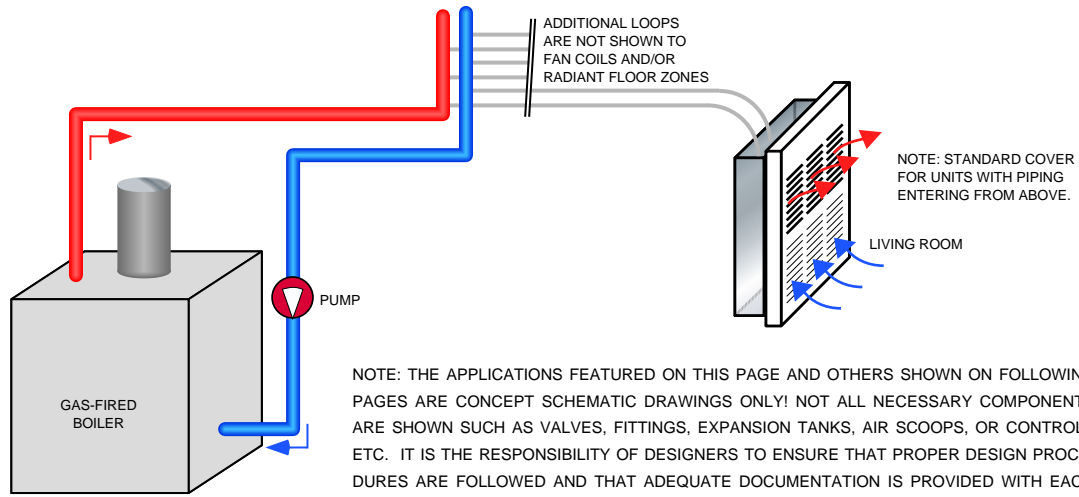
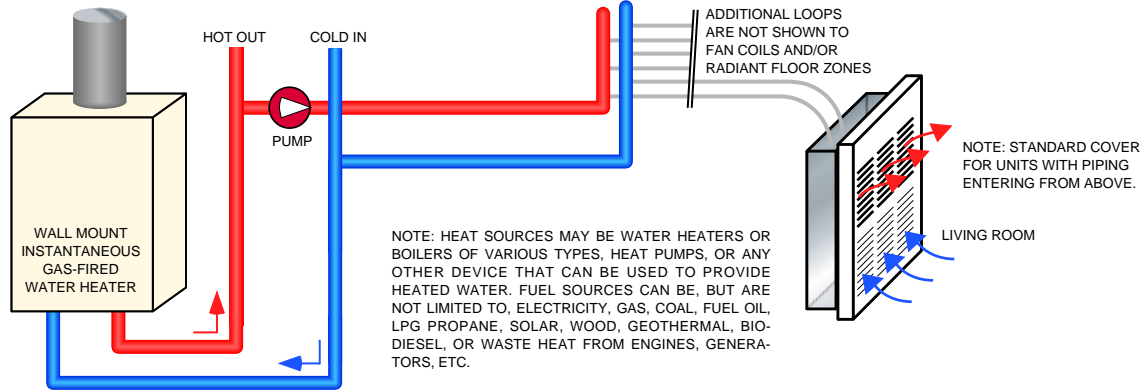

NOTE: THE APPLICATIONS FEATURED ON THIS PAGE AND OTHERS SHOWN ON FOLLOWING PAGES ARE CONCEPT SCHEMATIC DRAWINGS ONLY! NOT ALL NECESSARY COMPONENTS ARE SHOWN SUCH AS VALVES, FITTINGS, EXPANSION TANKS, AIR SCOOPS, OR CONTROLS ETC. IT IS THE RESPONSIBILITY OF DESIGNERS TO ENSURE THAT PROPER DESIGN PROCEDURES ARE FOLLOWED AND THAT ADEQUATE DOCUMENTATION IS PROVIDED WITH EACH ACTUAL APPLICATION. ALL INSTALLATIONS MUST CONFORM TO LOCAL AND/OR NATIONAL CODES.

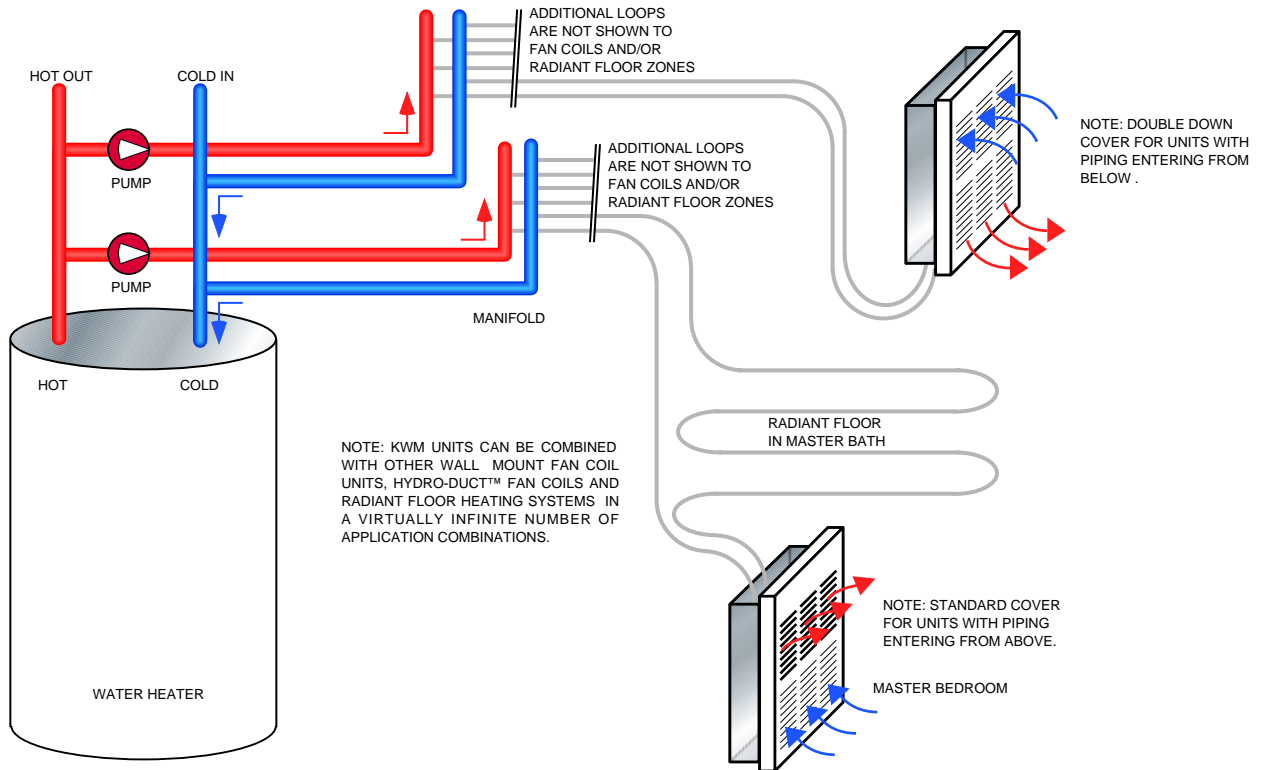

NOTE: KWM UNITS CAN BE COMBINED WITH OTHER WALL MOUNT FAN COIL UNITS, HYDRO-DUCT™ FAN COILS AND RADIANT FLOOR HEATING SYSTEMS IN A VIRTUALLY INFINITE NUMBER OF APPLICATION COMBINATIONS.

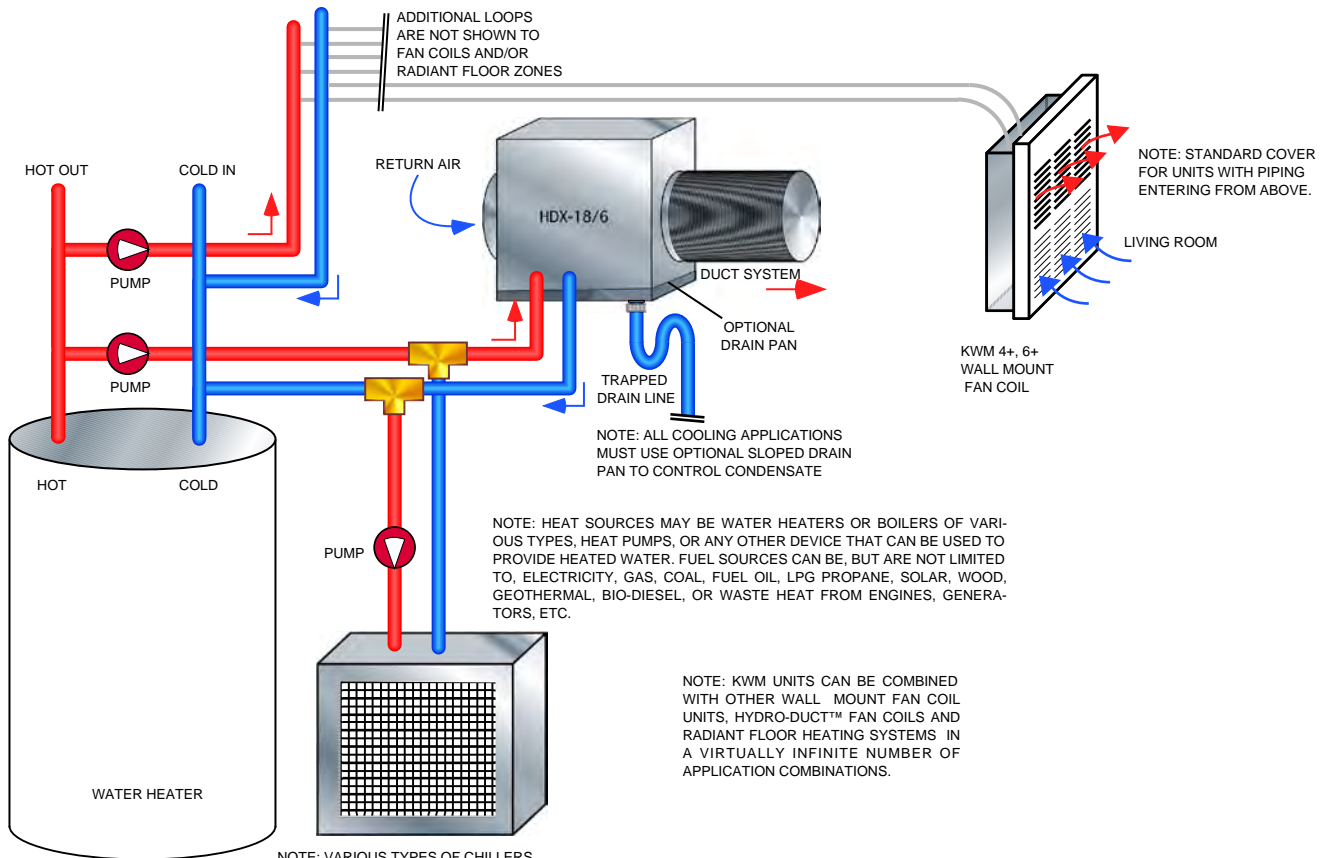
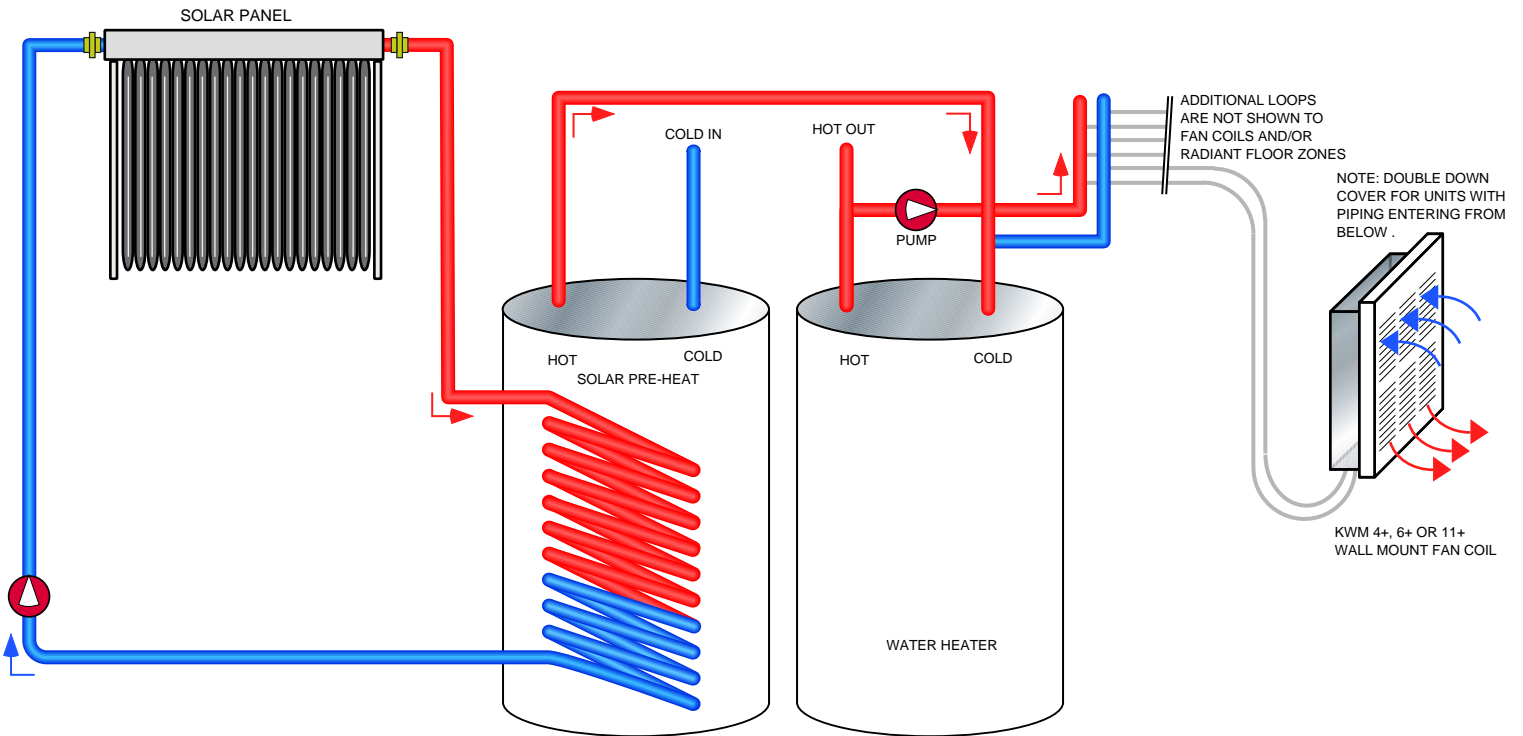

NOTE: THESE TWO SEPARATE FLOOR PLANS ARE FROM ACTUAL PROJECTS.

KEY

- Ⓢ SUMMER/WINTER SWITCH
- Ⓣ THERMOSTAT

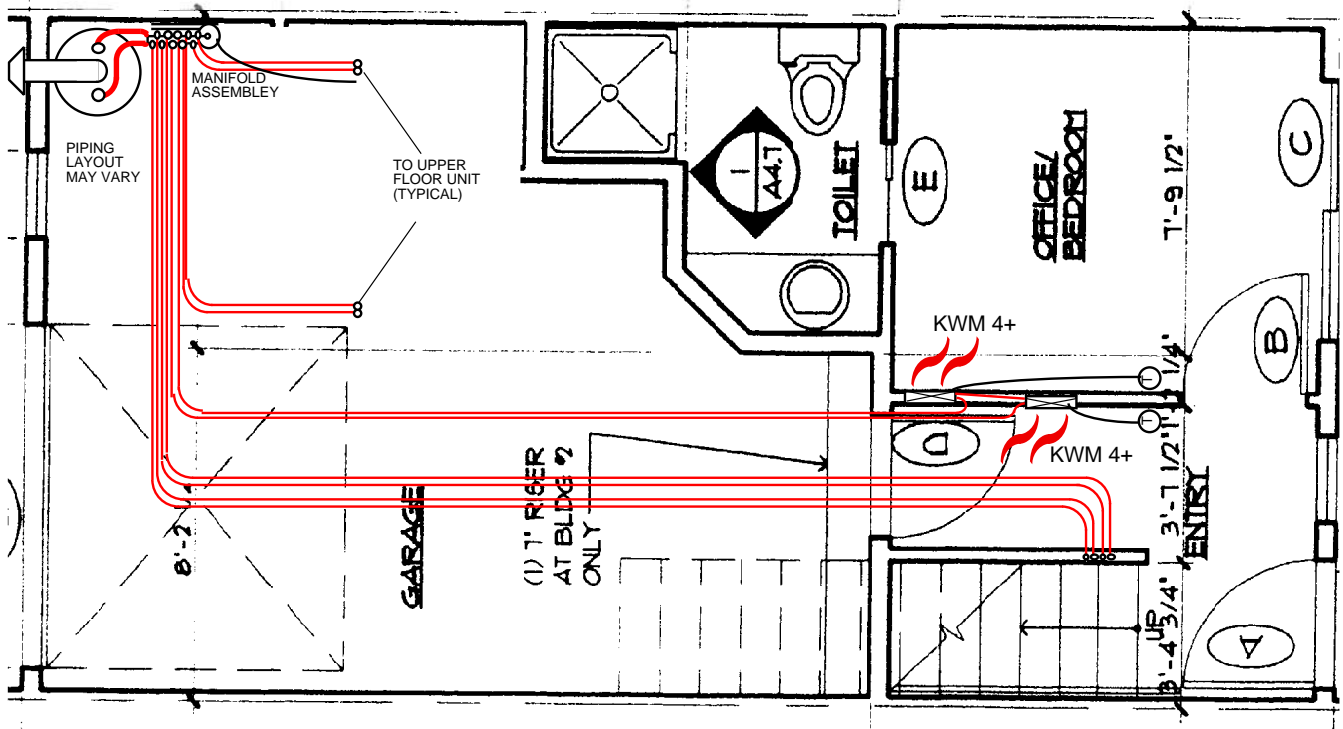
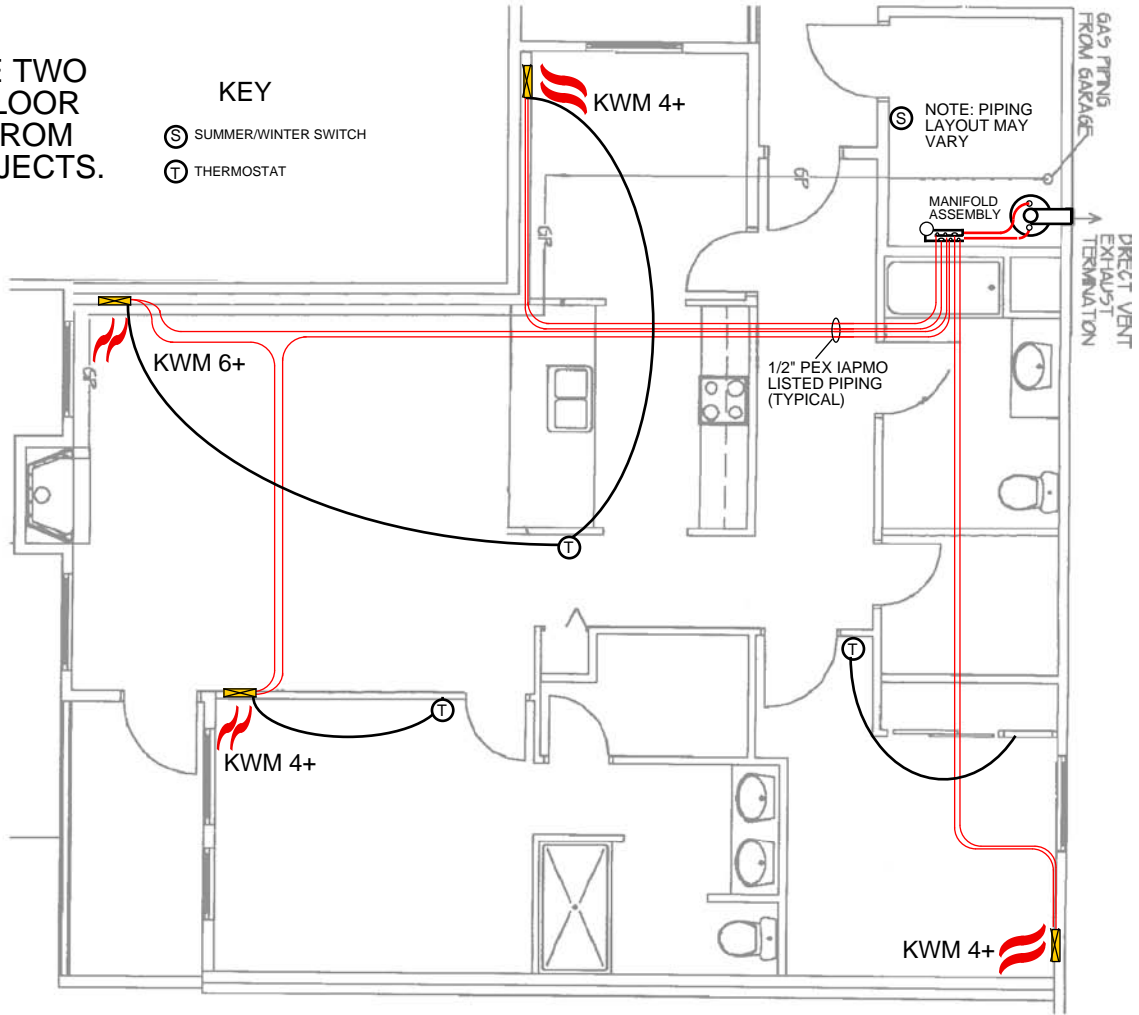

Model KWM 4+, KWM 6+ AND KWM 11+

INSTALLATION INSTRUCTIONS

KICKSTER™ WM+ SERIES HYDRONIC FAN COIL UNITS

GENERAL NOTES

The following reference instructions are available to help the installer as well as a reference source for the service technician. Installer should pay careful attention to the words: **NOTE**, **CAUTION**, and **WARNING** Notes are intended to make installation easier. **CAUTIONS** are given to prevent equipment damage. **WARNINGS** are given to alert the installer that personal injury and/or equipment damage may result if installation procedure is not followed.

1. Installation and maintenance are to be performed only by qualified personnel who are familiar with local codes and regulations, and experienced with this type equipment. **CAUTION: Sharp edges, coil surfaces and rotating fans are a potential injury hazard. Avoid contact.**
2. Maximum entering water temperature is 200 ° F.
3. May be used with potable water or other suitable fluid.

INSTALLATION

1. Examine unit for shipping damage.
2. Rotate fan wheels by hand to make sure the wheels rotate freely. Be careful not to hold the unit by its blower deck. The aluminum fins are very delicate and can be easily bent. Once bent, they are almost impossible to fix. Bent or flattened fins may cause excessive vibration or noise and can affect airflow.
3. Secure unit in proper position. Unit must be level to assure proper drainage and operation. Leveling is done with mount brackets (Refer to "A" in diagram on page 5).
4. Piping must be installed in accordance with local codes and regulations.
5. Vent the coils when first filling coil with water.
6. All water and drain lines should be well insulated to prevent sweating and heat loss. Coil connection nearest to front of unit is always supply.

7. Electrical connections can now be made to the electrical box. Access to the box can be obtained by removing the sheet metal cover plate on the back of the unit. For power supply connection, remove plastic grommet and replace with conduit and connector. Refer to nameplate FLA, maximum fuse size and minimum circuit ampacity. Also see wiring diagram affixed to the unit to make control and power wiring connections.

8. If the unit is equipped with a disconnect switch, the conduit and connector should be attached to the junction box containing the switch. Note: The wires hanging from the disconnect switch are for factory testing purposes.

9. The installer shall provide power to the unit, branch circuit overcurrent protection, any valve actuators, and disconnect means to conform with the applicable electrical code. Motor is "impedance protected".

10. All windows and doors should be in and closed before starting up the unit.



NOTE: WHEN USING DOUBLE DOWN COVERS ON 4+ OR 6+ MODELS IT IS POSSIBLE TO FLIP THE 2 SPEED SWITCH.



TURBONICS, INC.

MANUFACTURER OF HYDRONIC FAN COILS

A WORD ABOUT SHORT CIRCUITED AIR FLOW SYNDROME

Unit Output Capacity and the effectiveness of the units ability to provide comfort in a room are dependent on several factors. Design, construction, core ratings, air flow, air velocity, fluid flow rate, supply temperature of fluid and the temperature of the entering air all play a major role in determining whether an occupant of a room will experience perfect human thermal comfort. Of course it is important that a unit is properly sized to adequately satisfy the calculated heat load and it is generally assumed that this has been done by professionals. Professional HVAC designers try to create a circular airflow to touch the farthest point of the room, preventing drafts and “layering” that can cause discomfort. Furniture that is placed in front of a fan coil unit will restrict air flow, causing occupants to move furniture if necessary. But what happens when just plain poor product design allows air from the supply outlet to short circuit or flow into the supply inlet of a fan coil device?

Actual output capacity can be reduced by as much as 15 to 25% or more depending on the room that is being heated. As in Fig. 1 poor product design allows air from the supply to be drawn back into the units air intake. The cause for this is insufficient air velocity and poor louver design. The result is a further reduction in velocity which defeats the units ability to throw heat into the room and a significant reduction in rated capacity as inlet air is “pre-heated”. Heated air basically sits in front of the unit and the room is not adequately heated to proper comfort levels.



FIG. 1 BRAND K SMOKE TEST



FIG. 2 KWM+4 SMOKE TEST

As in Fig. 2 excellent product design ensures proper air velocity and good louver design prevents the short circuit of supply air into the air inlet. The result is more heated air is distributed into the room while the unit operates at full rated capacity. So by properly positioning your furniture and by using great products with proper design, perfect human thermal comfort can easily be achieved.

TURBONICS, INC.

MANUFACTURER OF HYDRONIC FAN COILS

ENGINEERING SPECIFICATIONS

KWM series fan coils are designed to be mounted between studs before sheet rock or dry-wall. They can be mounted after drywall if used with optional Flexible Connector Kits. They are suitable for connection to hot water supplies at any pressure up to 125 psi. Maximum water temperature should not exceed 200°F. The amount and temperature of water flowing through the coil, and air flow determines output capacities.

Turbonics, Inc. Designs and Builds it's Fan Coil Products to Comply and Perform to the following standards:

Hydronic Coil	Copper with Aluminum fin	KWM units use L/ASTM B75Copper and have been IAPMO tested and passed ANSI/NSF 61 Section 4 percolation test and are therefore suitable for use with potable water systems
Unit Assembly		
Sample Specification: Unit(s) with the necessary output to supply the load in each installed area shall be mounted within a suitable location that provides access for servicing and may be connected to a properly designed and balanced piping system. Copper coil with L/ASTM B75Copper and aluminum fins (or comparable material) tested in accordance with ANSI/NSF 61 Section 4 percolation test and suitable for use with potable water systems. Maximum water temperature of 200°F, and a pressure rating up to 125 psi. Propeller style fan is desired to provide quiet operation and easy cleaning, service or replacement. Unit must include, factory wired low-temp. aquastat, 2-speed, impedance protected, 2 pole motor with heavy bearings and may be controlled with remote wall mounted thermostat and/or variable speed fan control. Unit(s) to have minimum of CSA approval. 5 year limited manufacturers warranty. Locking screws for cover if required are supplied by others.		

Distributed by: